

CAPACITY	SYMBOL/SERIAL NO.	CIRCUIT DIAGRAM
DC 24V		
5W		

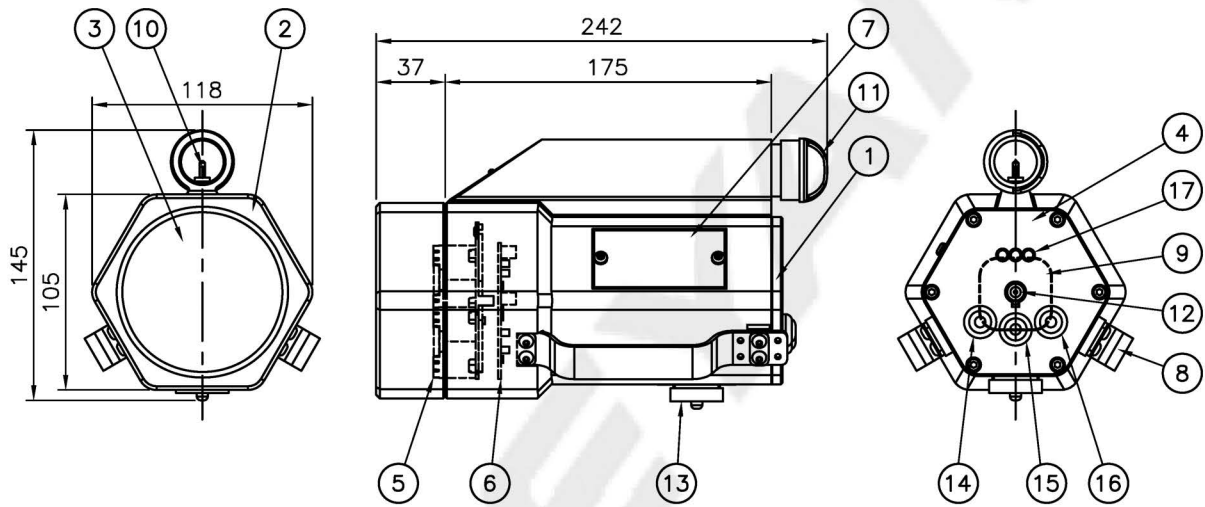

17	BATTERY INDICATOR LAMP	-	1						
16	SWITCH (MANUAL)	-	1		8	GRIP	-	2	
15	SWITCH (POWER)	-	1		7	NAME PLATE	STAINLESS STEEL	1	
14	SWITCH (AUTO_SOS)	-	1		6	LED driver	-	1	
13	POWER CONNECTOR	-	1	DC24V	5	LED module	-	1	
12	POWER CONNECTOR	-	1	AC100-220V	4	REAR COVER	PPS	1	
11	EYEPIECE SHIELD	-	1		3	GLOBE	POLYCAR-BONATE	1	
10	FOCUS PIN	STAINLESS STEEL	1		2	FRONT COVER	GN7142F	1	
9	BATTERY	-	1		1	BODY	PPS	1	
NO	NAME OF PARTS	MATERIAL	Q'TY	REMARKS	NO	NAME OF PARTS	MATERIAL	Q'TY	REMARKS

APPROVED	J. W. PARK	UNIT	MM	TITLE; <b>LED PORTABLE DAYLIGHT SIGNALLING LAMP FOR MARINE USE</b>
CHECKED	O. J. KWON	SCALE	N/S	
DRAWING	J. H. LEE	COLOR	BLACK	
DATE	2022.10.11	IP	56	

	MODEL NO.	DDS-05LBC	WEIGHT	1.75 Kg
	DRAWING NO.	L32700094	SHEET NO.	1

LIST OF CONTENTS

NAME	Q'TY	APPROX. WEIGHT(kg)
DAYLIGHT SIGNALLING LAMP	1	1.75 Kg
LED module (SPARE)	1	0.16 Kg
CABTYRE CORD	5 M	0.79 Kg
RED FILTER	1	0.02 Kg
GREEN FILTER	1	0.02 Kg
CHARGER	1	0.13 Kg

DAYLIGHT SIGNALLING LAMP

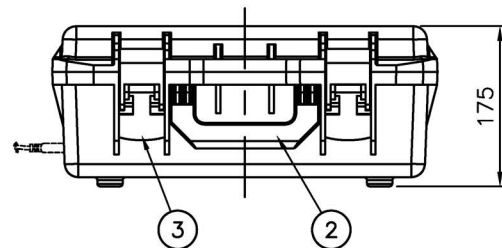
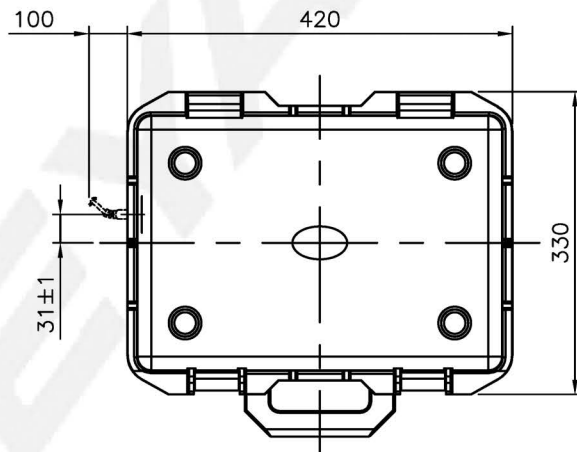
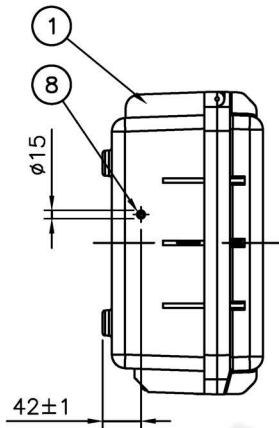
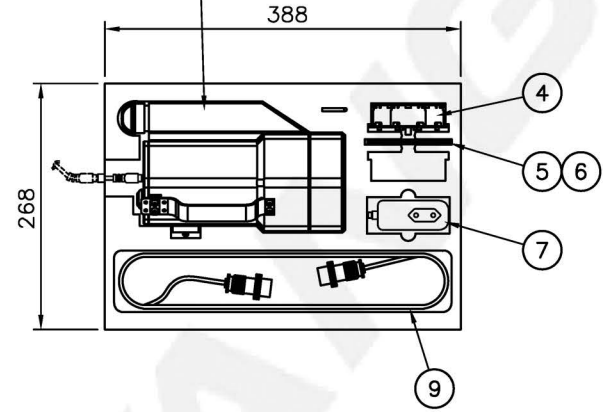

9	CABTYRE CORD(DC)	-	1	5M					
8	CHARGER CONNECTOR	-	1	W/CAP	4	LED module	-	1	FOR SPARE
7	CHARGER	-	1		3	COVER LOCK	ABS	1	
6	FILTER(GREEN)	-	1		2	HANDLE	ABS	1	
5	FILTER(RED)	-	1		1	BOX	ABS	1	
NO	NAME OF PARTS	MATERIAL	Q'TY	REMARKS	NO	NAME OF PARTS	MATERIAL	Q'TY	REMARKS

APPROVED	J. W. PARK	UNIT	MM
CHECKED	O. J. KWON	SCALE	N/S
DRAWING	J. H. LEE	COLOR	BLACK
DATE	2022.10.11	IP	67

TITLE;  
 CONTAINER BOX FOR PORTABLE  
 DAYLIGHT SIGNALLING LAMP  
 FOR MARINE USE

	MODEL NO.	DDS-05LBC	WEIGHT	5.3 Kg
	DRAWING NO.	L32700094-1	SHEET NO.	1-1

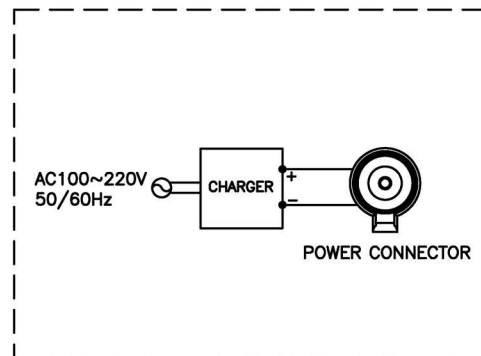
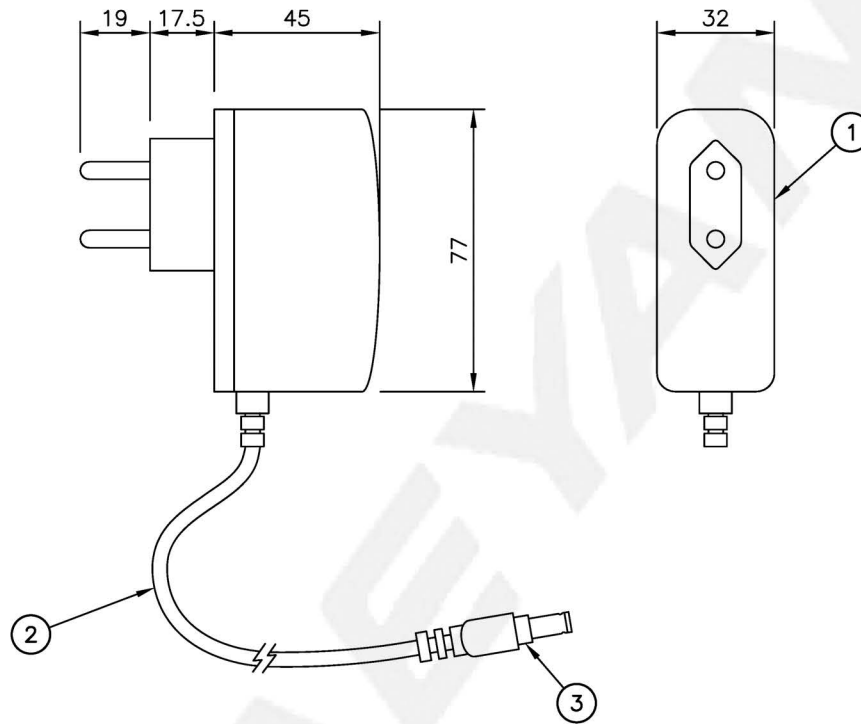

WIRING DIAGRAM

				2	CABLE	-	1	1.5M	
3	POWER CONNECTOR	-	1	1	CHARGER & PLUG	-	1		
NO	NAME OF PARTS	MATERIAL	Q'TY	REMARKS	NO	NAME OF PARTS	MATERIAL	Q'TY	REMARKS
APPROVED	J. W. PARK	UNIT	MM	TITLE; BATTERY CHARGER FOR DAYLIGHT SIGNALLING LAMP FOR MARINE USE					
CHECKED	O. J. KWON	SCALE	N/S						
DRAWING	J. H. LEE	COLOR	BLACK						
DATE	2022.10.11	IP	20						
					MODEL NO.	DDS-05LBC	WEIGHT	0.13 Kg	
					DRAWING NO.	L32700094-2	SHEET NO.	1-2	